

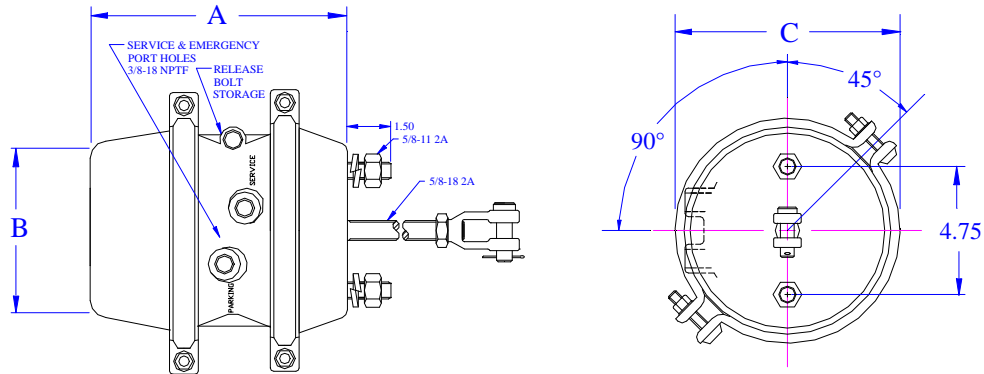

SPRING BRAKES/DC MODELS

Committed
To Quality...

TECHNICAL DATA



PART NO	SIZE	MODEL	WEIGHT	STROKE	DIM. A	DIM. B	DIM. C
12350	2424	DC	17.0 lbs	2.50"	8.85 in.	5.30 in.	7.50 in.
12450	2430	DC	18.80 lbs	2.50"	9.10 in.	6.50 in.	8.25 in.
12550	3030	DC	20.10 lbs.	2.50"	9.10 in.	6.50 in.	8.25 in.

**DC=DOUBLE CLAMP UNIT

DESIGN FEATURES

