

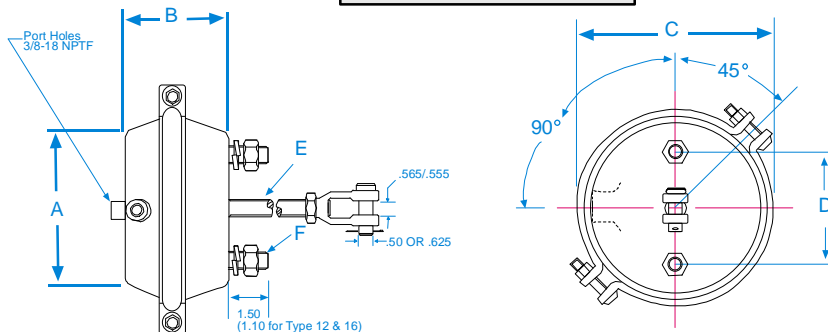

AIR BRAKE SERVICE CHAMBERS

Committed
To Quality...

TECHNICAL DATA



PART NO	TYPE	WEIGHT	STROKE	DIM. A	DIM. B	DIM. C	DIM. D	DIM. E	DIM. F	DIM. G
10100	12	4.84 lbs.	1.75 in.	3.6 in.	3.1 in.	5.8 in.	3.00 in.	1/2 x 20	7/16 x 20	1/4 NPTF
10200	16	6.15 lbs.	2.25 in.	4.2 in.	3.6 in.	6.5 in.	3.00 in.	1/2 x 20	7/16 x 20	1/4 NPTF
10300	20	7.76 lbs.	2.25 in.	4.9 in.	3.8 in.	7.0 in.	4.75 in.	5/8 x 18	5/8 x 11	3/8 NPTF
10400	24	8.38 lbs.	2.50 in.	4.9 in.	4.0 in.	7.5 in.	4.75 in.	5/8 x 18	5/8 x 11	3/8 NPTF
10500	30	10.00 lbs.	2.50 in.	5.5 in.	4.1 in.	8.3 in.	4.75 in.	5/8 x 18	5/8 x 11	3/8 NPTF
10600	36	12.54 lbs.	3.00 in.	6.5 in.	4.4 in.	9.2 in.	4.75 in.	5/8 x 18	5/8 x 11	3/8 NPTF
10800	24ELS	8.70 lbs.	3.00 in.	4.9 in.	4.4 in.	7.5 in.	4.75 in.	5/8 x 18	5/8 x 11	3/8 NPTF
10900	30ELS	10.05 lbs.	3.00 in.	5.5 in.	4.4 in.	8.2 in.	4.75 in.	5/8 x 18	5/8 x 11	3/8 NPTF

**ELS = EXTENDED LONG STROKE

DESIGN FEATURES

ALL STEEL CONSTRUCTION

- PREMIUM DIAPHRAGMS
- MUSIC WIRE RETURN SPRING
- FRICTION WELDED PUSH RODS
- HEAVY 10 GAGE NON-PRESSURE HOUSING
- PUSH ROD DIRT SHIELD
- EXTRA STUD REINFORCEMENT
- FORGED STEEL CLEVIS

